

Powerful Marine Searchlights

“Rugged Design... with Powerful Beam”

Features



Chrome Finish seen above

- **Powerful Beams... over 2KM range!**
 - 1.0** Million Candela (10-inch/254mm Diameter)
 - 1.6** Million Candela (12-inch/305mm Diameter)
 - 3.0** Million Candela (15-inch/381mm Diameter)
- **Materials/Finish...** Head and Yoke Arms are High Quality Brass and Stainless Steel Materials, with Sparkling Chrome, or Salt-Resistant Marine Powder Coat Finish.
- **Rugged Motorized Base...** same as used on Coast Guard Patrol Boats with rugged Drive Assembly... and dynamic braking immediately stops Beam on target!
- **Anti-shock Lamp holder Design...** increases lamp-life, and helps protect filament when fixture is impacted by bullets, rocks, etc,
- **Anti-condensation Heater...** standard in base which helps prolong life of electrical components.
- **Wide Range of Voltages...** 115 VAC, 220VAC, 12VDC and 24VDC.
- **Multiple Weatherproof Controls...** unlimited stations control same light... and weatherproof versions for outdoor use.
- **Anti-icing Heaters (optional)**

“Leaders in Searchlight Technology since 1894”...

This searchlight family is used widely throughout the U.S. Navy, U.S. Coast Guard and worldwide for Commercial Marine and Security Applications. It is a rugged, high quality Brass and Stainless Fixture, with a powerful Beam which will project from 1 to over 2KM, depending upon the fixture selected. The beam will immediately stop when the target is sighted, with built-in electric braking. The rotation is beyond a full circle (385°) with a unique sliding stop design. The anti-condensation heater will increase the life of the electrical parts in the base.



Used widely throughout the
U.S. Coast Guard!



NOTE: Visit www.carlisefinch.com and select “marine searchlights” to find dimensions and additional product specifications.

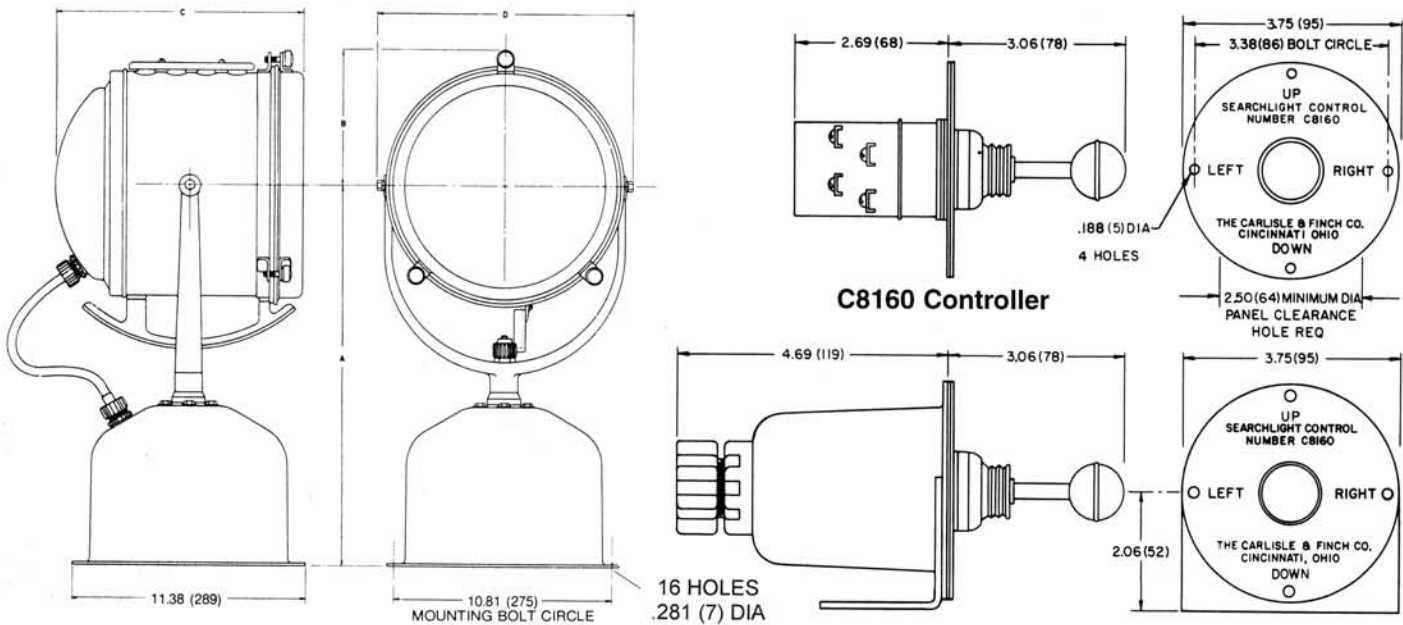

SIZE	A	B	C	D
10-Inch	18.18(462)	6.00(152)	10.00(254)	11.00(279)
12-Inch	20.12(511)	7.12(181)	13.25(337)	13.75(349)
15-Inch	24.06(611)	8.00(203)	15.00(381)	16.75(425)

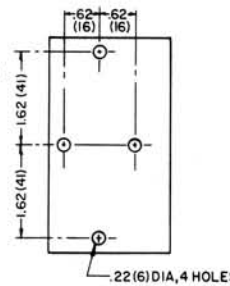

8171X Enclosure and Bracket Assembly (with controller installed).
Polished chrome finish over brass.

***** NOTE *****

**220 VOLTS and 24 VOLTS OFFERED.
CONSULT FACTORY**

SEARCHLIGHT SELECTION TABLE

The complete catalog number must include a suffix for the lampholder desired. Add one of the following suffixes to the basic catalog number: medium screw lampholder, -1; medium prefocus, -2; mogul screw, -3; mogul bipost, -4; 2-pin prefocus, -5.

Size	Drum	Base	SEARCHLIGHT CATALOG NUMBER			Weight lb (kg)	
			Enamel Finish	Polished Finish	Chrome Finish	Net	Ship
10-Inch	Non-Vented	Aluminum	105AE	105AP	105AC	30(14)	40(18)
		Brass	105BE	105BP	105BC	35(16)	45(20)
12-Inch	Non-Vented	Aluminum	125AE	125AP	125AC	35(16)	46(21)
		Brass	125BE	125BP	125BC	40(18)	51(23)
	Vented	Aluminum	125AEV	125APV	125ACV	35(16)	46(21)
		Brass	125BEV	125BPV	125BCV	40(18)	51(23)
15-Inch	Non-Vented	Aluminum	155AE	155AP	155AC	51(23)	65(29)
		Brass	155BE	155BP	155BC	56(25)	70(32)
	Vented	Aluminum	155AEV	155APV	155ACV	51(23)	65(29)
		Brass	155BEV	155BPV	155BCV	56(25)	70(32)

HOW TO ORDER SEARCHLIGHT SYSTEMS

Specify quantity Distant Electric Control (DEC) Searchlight, size, drum, base material, finish, and lampholder desired. Give searchlight catalog number from table above and add suffix for lampholder type. Specify quantity controller C8160, with or without Enclosure and Bracket Assembly 8171X. Specify quantity lamps and give volts, watts, and ordering code from lamp list.

Order Example:

2 DEC Searchlight, 12", vented, aluminum base, enamel finish, medium prefocus lampholder, catalog no. 125AE-2.

4 Controller C8160

4 Enclosure and Bracket Assembly 8171X

4 Lamp, 120V, 1000W, code BTR